



# Bending Copper Tubes - Setting Out for Spring Loading

There is little difficulty bending light gauge tubes once the necessary skills have been developed and practised. This article illustrates and describes methods of setting out bends without the use of elaborate drawings. These methods can quickly enable high quality, accurate bends to be formed on copper tubes without "wrinkling" or flattening.

Bending springs are used to support the tube walls while the bend is made. Springs are available for all EN 1057 "Kite marked" standard tube diameters in both half-hard thin and thick wall tube formerly table X and Y from 10 to 22mm, which is the maximum recommended for spring loading. It is possible to bend half - hard thin wall (table X) tubes up to 22mm diameter by hand without softening provided care is taken. Whilst most people who work with copper tube know that good quality copper tubing is made in accordance with a British Standard, not so many seem to be aware that there is also a matching British Standard for bending springs (B.S. 5431) which means that correctly sized springs are available for all of the different tube diameters and wall thicknesses.

It is important to use the correct sized spring to support the tube walls during bending. If the spring used is undersized then this can cause wrinkling or even result in good quality tube snapping during bending. Another

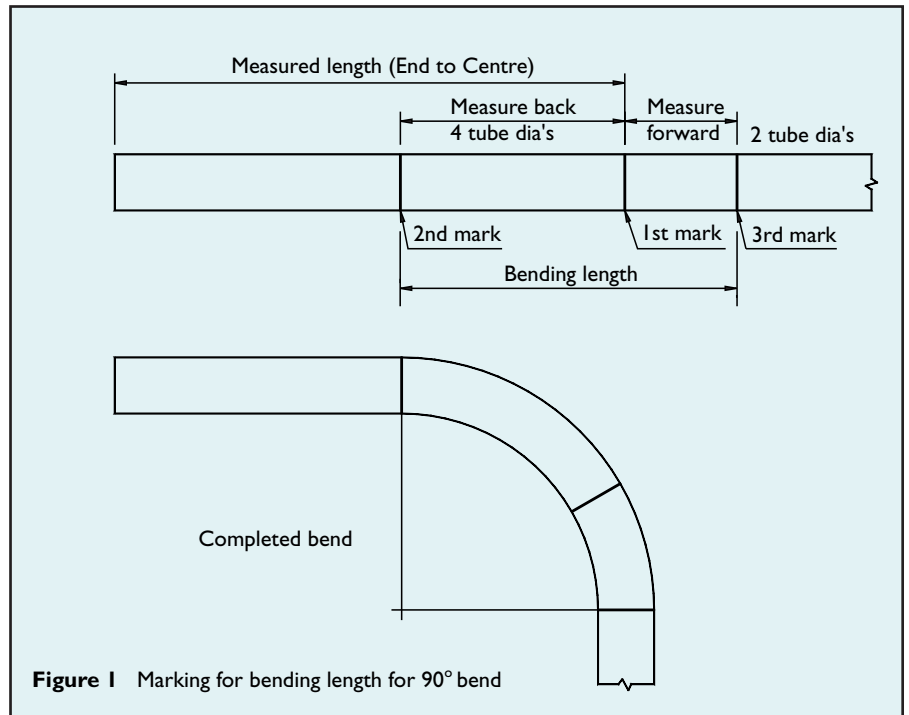

Figure 1 Marking for bending length for 90° bend

common cause of tube snapping during bending is the use of rusty springs. Applying a little grease or lubricating oil to the spring before use will both assist the bending operation and prolong the life of the spring.

## Marking out of bending lengths

When bending there are advantages to be gained by marking out the bending length. For example: the position of the bend can be made more accurately, saving tube and time; also, the bend throat is not likely to wrinkle, because

the bend will be made to the correct radius.

There are two factors to consider when setting out. These are: the 'gain' of material when the bend is pulled and the bending point.

## The 'gain' of material

When a tube is bent to pass around a corner or an obstruction the tube takes a 'short cut' and so tube is gained. The actual amount of tube gained depends on the angle through which the bend is pulled and the bend radius to be used. This radius in turn depends on the diameter of the tube. As a general rule: **The radius of a spring loaded bend should be equal to 4 times the outside diameter of the tube.** This radius is slightly greater than the radius of a typical machine - made bend but, choosing a radius of 4 tube diameters simplifies setting out. Note, the minimum bend radius measured to the throat is 3 tube diameters for all tube sizes.

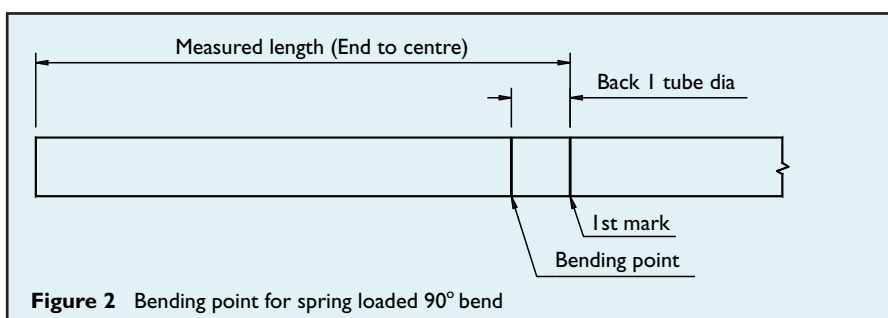
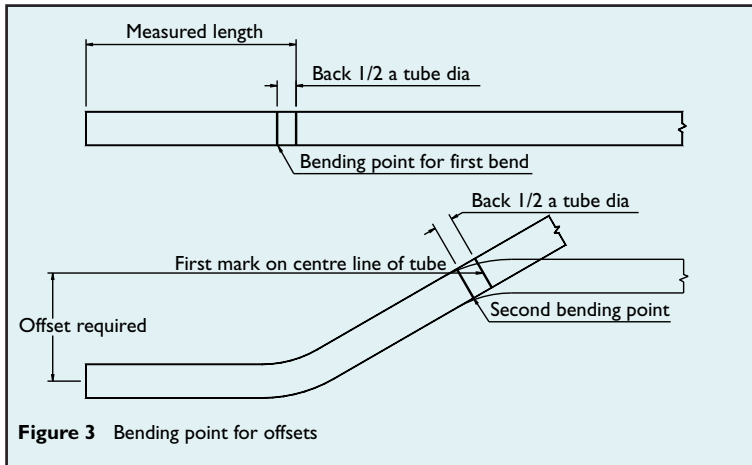
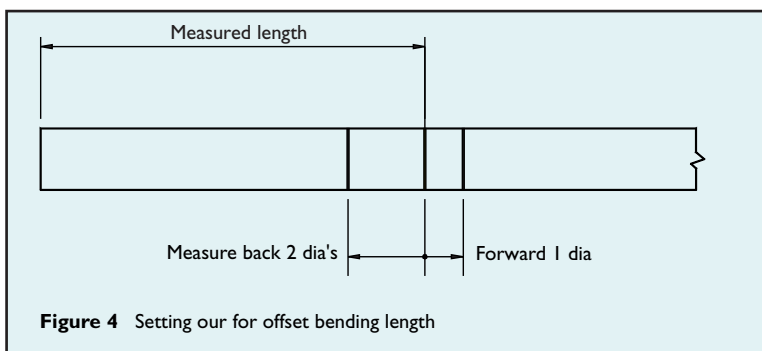

Figure 2 Bending point for spring loaded 90° bend



**Figure 3** Bending point for offsets



**Figure 4** Setting out for offset bending length

For example to mark out the bending length for a spring loaded 90° bend on 22mm diameter tube 200mm from the end of the tube to the centre of the bend. See Figure 1.

First, mark the measured length position. In this example the mark will be 200mm from the end of the tube. Next, decide on the bending radius. Usually this will be 4 times the tube diameter. So,  $4 \times 22 = 88\text{mm}$ .

Now, mark the START of the bending length. The position of this mark is 4 tube diameters (88mm or one bend radius) BACK from the first mark. The last mark required is the END of the bending length. The position of this mark is 2 tube diameters (44mm or 1/2 a bend radius) FORWARD from the first mark.

Then insert the correct sized, lubricated spring and bend to the required angle.

### The bending point

With a bend radius equal to 4 diameters the 'gain' is 1 tube diameter. Figure 2 shows the bending point for a 90° bend, this is measured BACK 1 tube diameter from the measured length position. This gives the centre of the bend and the position where the knee should be placed if it is used to form the bend.

### Pulling power

As the bend is pulled the throat and back of the bend tighten on to the spring gripping it tightly. So, to make spring removal easier the bend should be pulled to an angle which is slightly more than necessary and then pulled back to the correct angle required. This releases pressure on the spring and should enable it to be pulled out without difficulty, especially if the spring is given a slight twist in the direction it is coiled as it is pulled. The effect of the twist is to reduce the spring diameter.

When bends of less than 90° are to be made, for single and double sets or pass-over bends, the 'gain' will be proportionately less

If the set is to be pulled through 45° the bending point will be 1/2 a tube diameter back from the measured length. As shown in Figure 3. Also, the bending length will be half of that required for a 90° bend. So, the start point for bending will be two tube diameters back from the measured length point and the finish point one tube diameter forward from the measured length point. As in Figure 4.

The methods of setting out described for 90° bends and 45° sets can also be used when forming partial or full tube pass-over bends. Remember to allow sufficient clearance where the tubes are to be insulated especially where correct water bylaw insulation thickness is to be used.

One advantage that a spring loaded bend can have over a machine bend is that the bend radius can be varied. This enables tube centres to be carried around bends. The appearance of the bends is improved because the radii are concentric and so they 'match' because the gap between the tubes is even. Figure 5 shows how to establish the outer bend radius. Once this is determined the increased radius is used to mark out the start and end of the softening length, as for the simple 90° bend described previously.

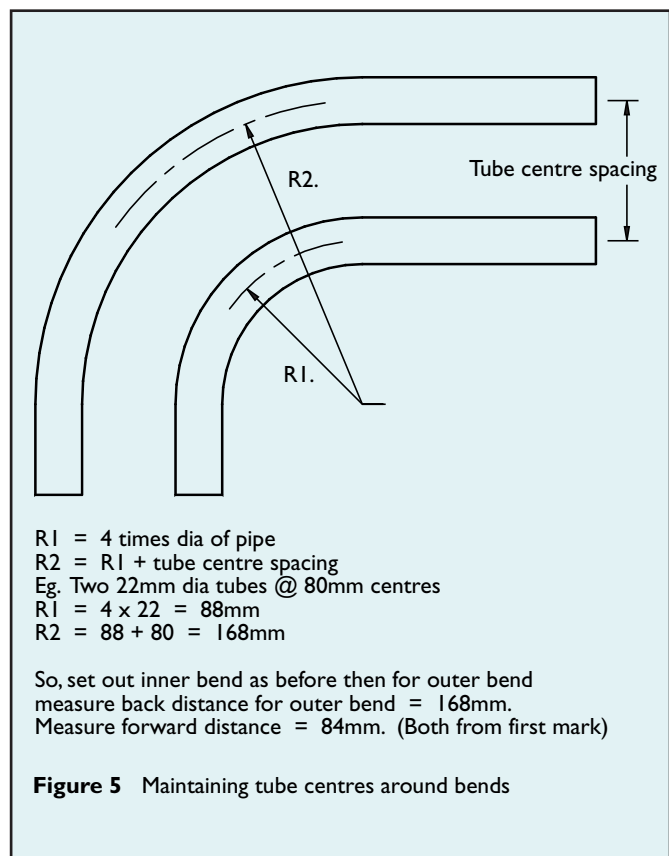

**Figure 5** Maintaining tube centres around bends